

Recommended P/N 20373-R**T-06

PART NO.	POS	A	B	C	D
20373-014T-00	14	10.2	6.7	11.4	5.2
20373-*20T-00	20	12.6	9.1	13.8	7.6
20373-*32T-00	32	17.4	13.9	18.6	12.4
20373-*35T-00	35	18.6	15.1	19.8	13.6
20373-040T-01	40	20.6	17.1	21.8	15.6
20373-050T-00	50	24.6	21.1	25.8	19.6

THE COMPOSITION OF PART No.
PART No. 20373-***T-0*

Pos.
14 : 14P 20 : 20P 32 : 32P
35 : 35P 40 : 40P 50 : 50P

HOUSING MATERIAL
0 : LCP, UL94V-0, BLACK
R : LCP, UL94V-0, BLACK
(RED PHOSPHORUS IS NOT USED/20P 32P 35P ONLY)

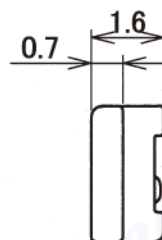
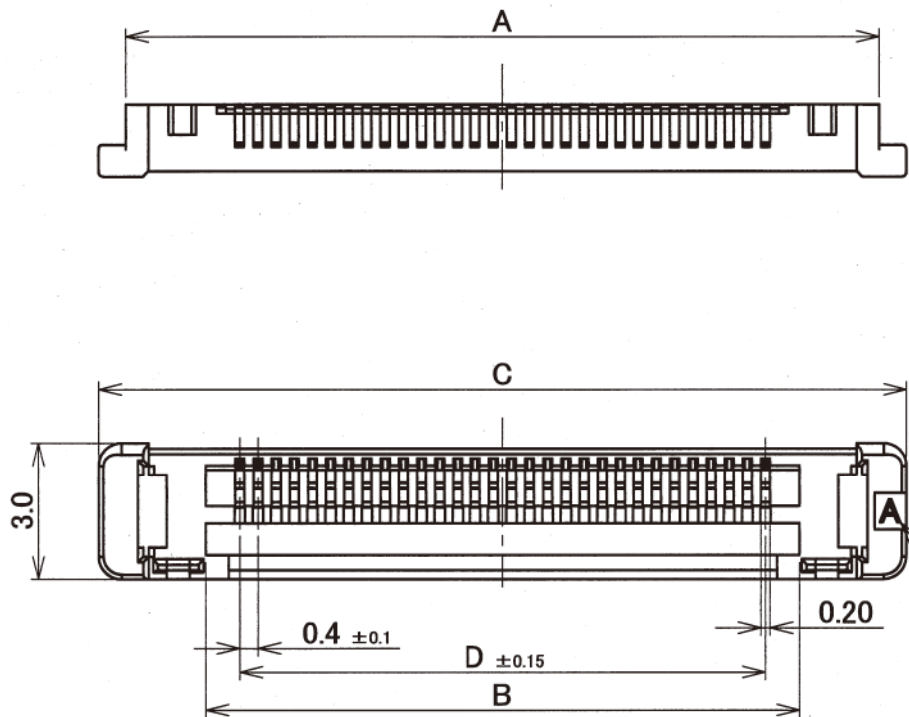

CAV.No.
A : 20373-0**T-00
◁ : 20373-R**T-00

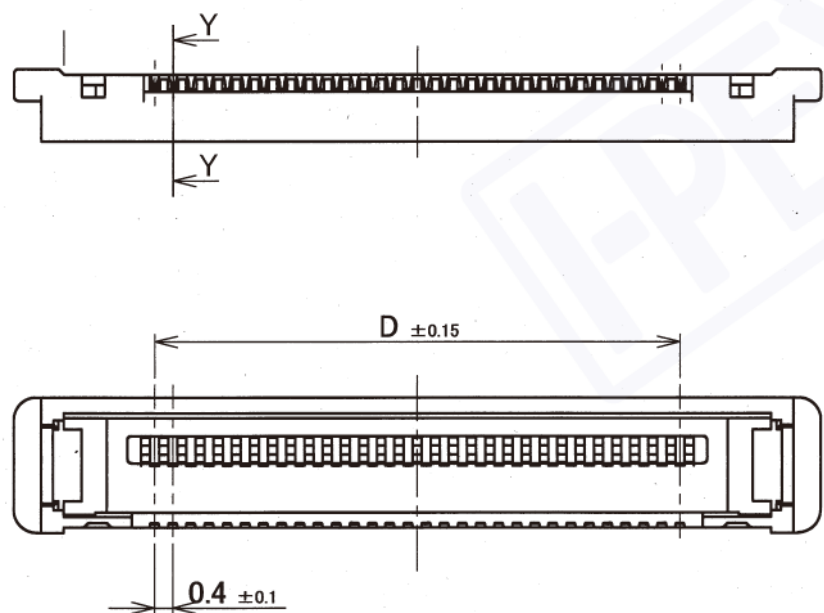
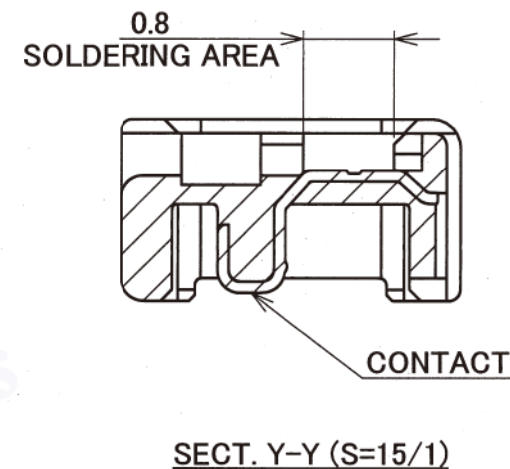

- NOTES
1.MATERIAL & FINISH
HOUSING : LCP UL94V-0, BLACK
CONTACT : COPPER ALLOY, Au OVER Ni
2.THIS PART IS ASSEMBLED WITH METAL COVER(P/N 2182-0**-0*)
AFTER SOLDERED THE COAXIAL CABLE, AND IT BECOMES
P/N 20380-***T-**

GENERAL TOLERANCE	
6 MAX.	±0.2
6 OVER MAX. 30	±0.3
30 OVER MAX. 120	±0.5
ANGLE	±2°

I-PEX DAI-ICHI SEIKO CO.,LTD.
I-PEX Business Company

TITLE
CABLIN-SS
PLUG HOUSING ASS'Y

SERIES No.	R8	CUSTOMER COPY	PROJECTION	SCALE	UNIT	DWG. No.	SHEET	REV.
				6:1	mm	20373	1/4	17

Recommended P/N 20373-R**T-06

PART NO.	POS	A	B	C	D	E
20373-*30T-00	30	16.6	13.1	17.8	11.6	13.1

SHAPE OF 30P

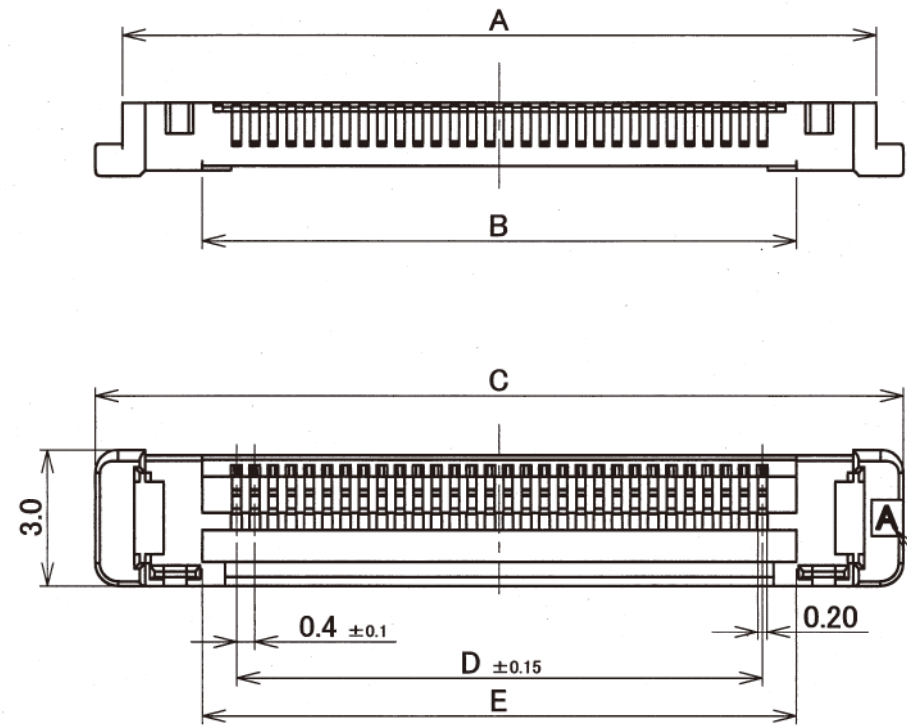

THE COMPOSITION OF PART No.
PART No. 20373-*30T-00

Pos.

HOUSING MATERIAL

0 : LCP, UL94V-0, BLACK

R : LCP, UL94V-0, BLACK

(RED PHOSPHORUS IS NOT USED)

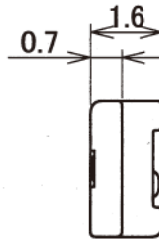

CAV.No.

A : 20373-030T-00

◁ : 20373-R30T-00

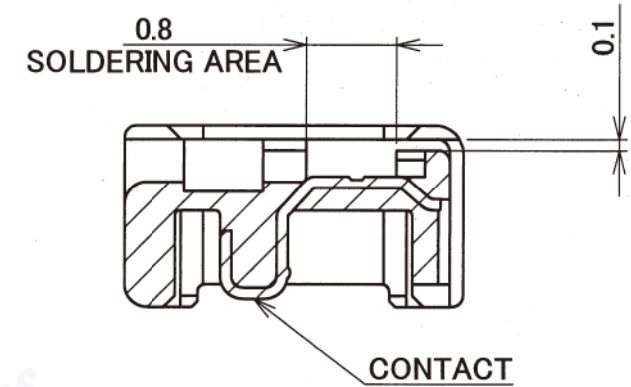

SECT. Y-Y (S=15/1)

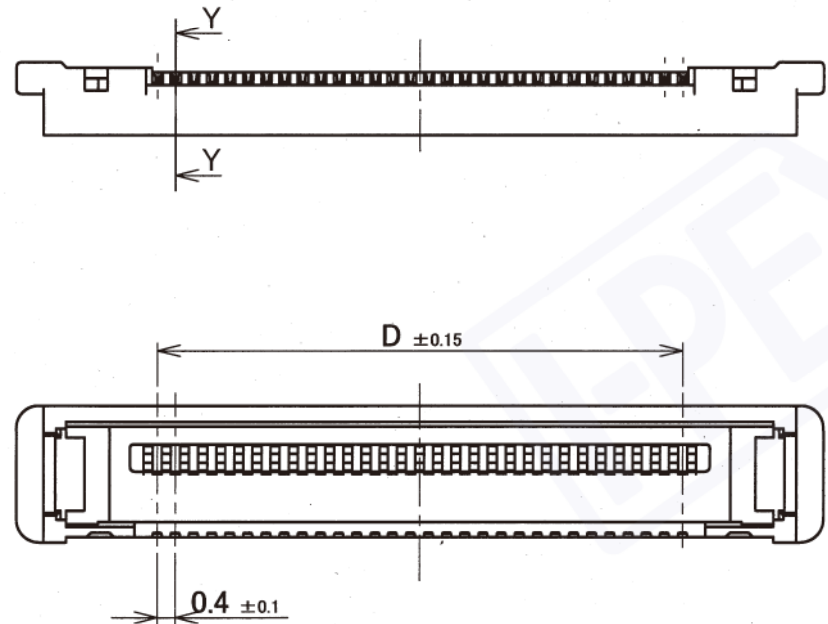

GENERAL TOLERANCE	
6 MAX.	±0.2
6 OVER MAX. 30	±0.3
30 OVER MAX. 120	±0.5
ANGLE	±2°

I-PEX DAI-ICHI SEIKO CO.,LTD.
I-PEX Business Company

TITLE
CABLIN-SS
PLUG HOUSING ASS'Y

CUSTOMER
COPY



SCALE
6:1

UNIT
mm

DWG. No.
20373

SHEET
2/4

REV.
17

Confidential III C

QKE-DFE06-02 REV.7

Recommended P/N 20373-RT-06**

PART NO.	POS	A	B	C	D
20373-*10T-03	10	8.6	5.1	9.8	3.6
20373-*14T-03	14	10.2	6.7	11.4	5.2
20373-*20T-03	20	12.6	9.1	13.8	7.6
20373-*30T-03	30	16.6	13.1	17.8	11.6
20373-*40T-03	40	20.6	17.1	21.8	15.6
20373-*50T-03	50	24.6	21.1	25.8	19.6

**THE COMPOSITION OF PART No.
PART No. 20373-***T-03**

FOR AWG #36,#40

Pos.
10 : 10P, 14 : 14P, 20 : 20P, 30 : 30P, 40 : 40P, 50 : 50P

HOUSING MATERIAL
0 : LCP, UL94V-0, BLACK
R : LCP, UL94V-0, BLACK
(RED PHOSPHORUS IS NOT USED)

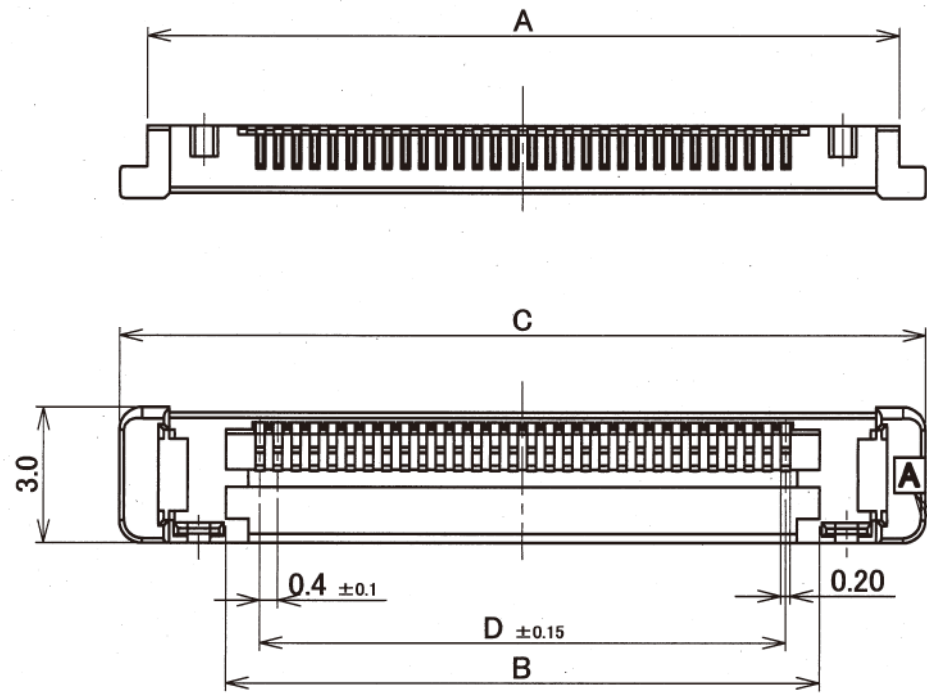

CAV.No.
A : 20373-0**T-03
< : 20373-R**T-03

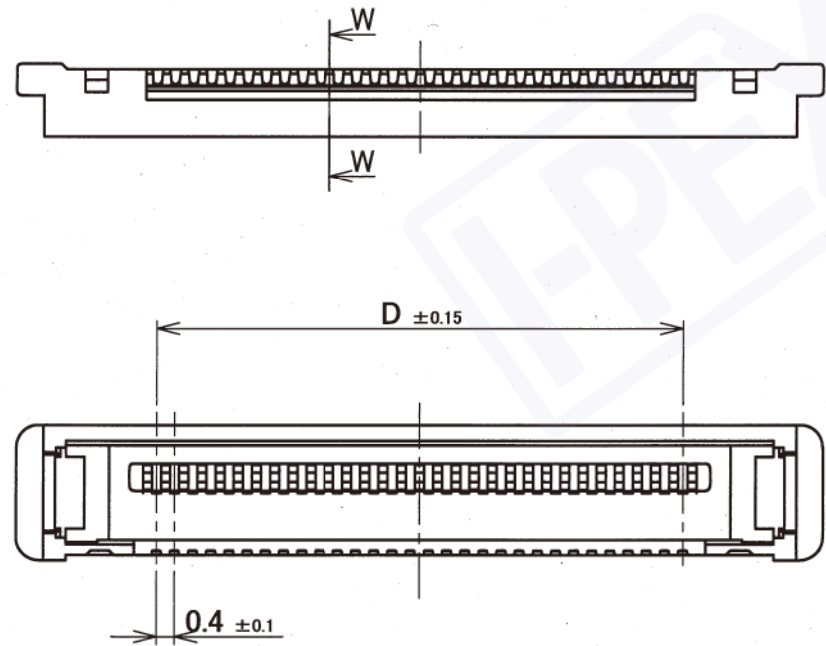
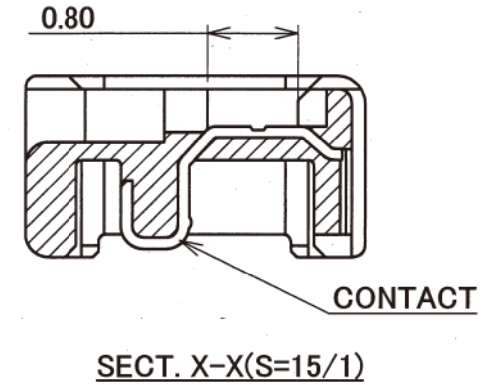

- NOTES
- MATERIAL & FINISH
 - HOUSING : LCP, UL94V-0 BLACK
 - CONTACT : COPPER ALLOY, Au OVER Ni.
 - THIS PART IS ASSEMBLED WITH METAL COVER (P/N 2182-0**-03) AFTER SOLDERED CABLE, AND IT BECOMES P/N 20380-***T-03

GENERAL TOLERANCE	
6 MAX.	±0.2
6 OVER MAX. 30	±0.3
30 OVER MAX. 120	±0.5
ANGLE	±2°

I-PEX DAI-ICHI SEIKO CO.,LTD.
I-PEX Business Company

TITLE
**CABLIN-SS
PLUG HOUSING ASS'Y**

CUSTOMER COPY	PROJECTION	SCALE	UNIT	DWG. No.	SHEET	REV.
		6:1	mm	20373	3/4	17

Recommended P/N		20373-R**T-06			
PART NO.	POS	A	B	C	D
20373-R10T-06-*	10	8.6	5.1	9.8	3.6
20373-R14T-06-*	14	10.2	6.7	11.4	5.2
20373-R20T-06-*	20	12.6	9.1	13.8	7.6
20373-R30T-06-*	30	16.6	13.1	17.8	11.6
20373-R32T-06-*	32	17.4	13.9	18.6	12.4
20373-R35T-06-*	35	18.6	15.1	19.8	13.6
20373-R40T-06-*	40	20.6	17.1	21.8	15.6
20373-R50T-06-*	50	24.6	21.1	25.8	19.6

THE COMPOSITION OF PART No.
PART No. 20373-R**T-06-*

FOR AWG #34

NOTHING: Minimum order quantity is 3200pcs.
S: Minimum order quantity is 480pcs.
Pos.
10 : 10P, 14 : 14P, 20 : 20P, 30 : 30P,
32 : 32P, 35 : 35P, 40 : 40P, 50 : 50P

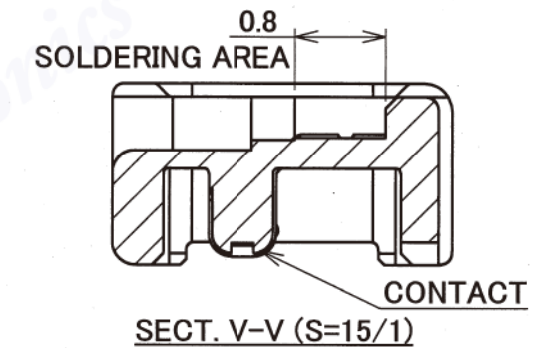
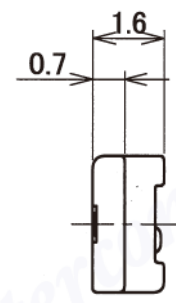
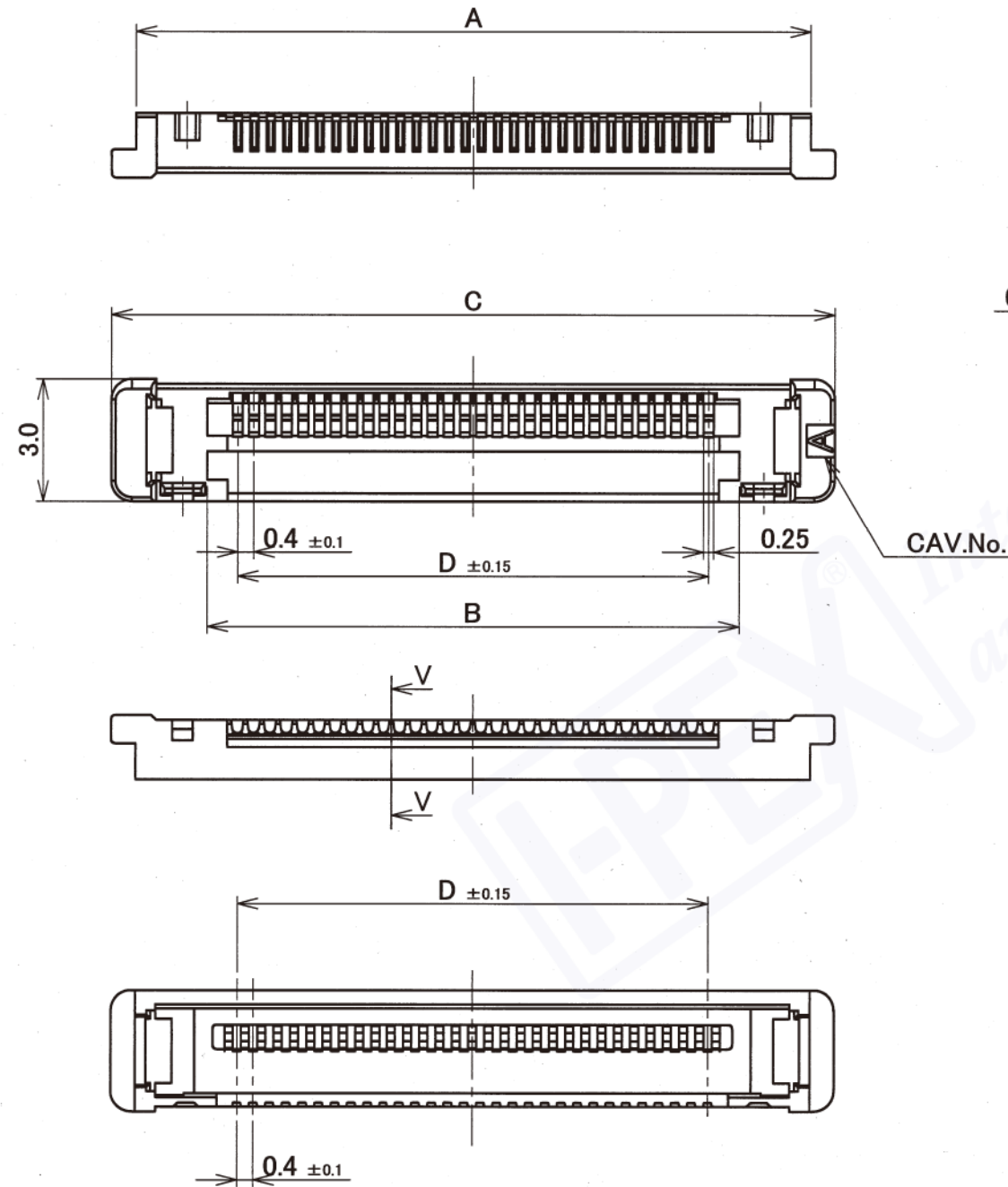

NOTES

- MATERIAL & FINISH
 - HOUSING : LCP, UL94V-0 BLACK (RED PHOSPHORUS IS NOT USED)
 - CONTACT : COPPER ALLOY, Au OVER Ni.
- THIS PART IS ASSEMBLED WITH METAL COVER (P/N 2182-0**-03) AFTER SOLDERED CABLE, AND IT BECOMES P/N 20380-R**T-06

GENERAL TOLERANCE	
6 MAX.	±0.2
6 OVER MAX. 30	±0.3
30 OVER MAX. 120	±0.5
ANGLE	±2°

I-PEX DAI-ICHI SEIKO CO.,LTD.
I-PEX Business Company

TITLE
CABLIN-SS
PLUG HOUSING ASS'Y

CUSTOMER COPY	PROJECTION	SCALE	UNIT	DWG. No.	SHEET	REV.
		6:1	mm	20373	4/4	17

Confidential III C