

Recommended P/N 20454-2\*\*T

PART NO.	POS.	A	B	C	D	E	F	G	H
20454-220T	20	9.50	10.30	12.56	10.20	10.55	11.00	16.00	-
20454-230T	30	14.50	15.30	17.56	15.20	15.55	16.00	21.00	5.40
20454-240T	40	19.50	20.30	22.56	20.20	20.55	21.00	26.00	10.40

# 20454-2\*\*T : STANDARD TYPE-A

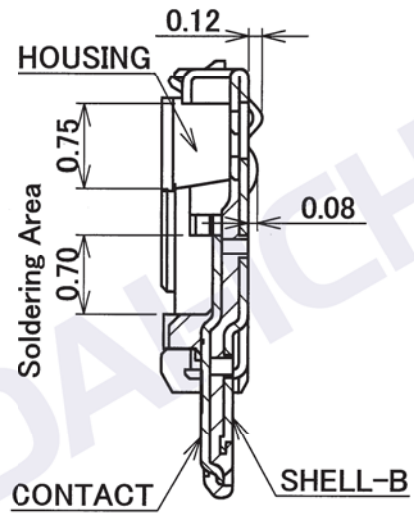
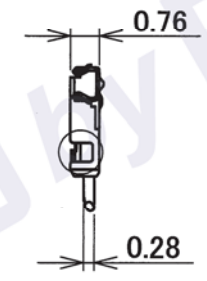
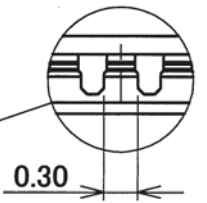
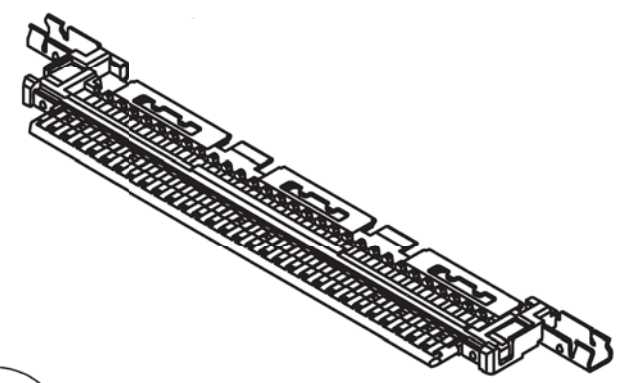
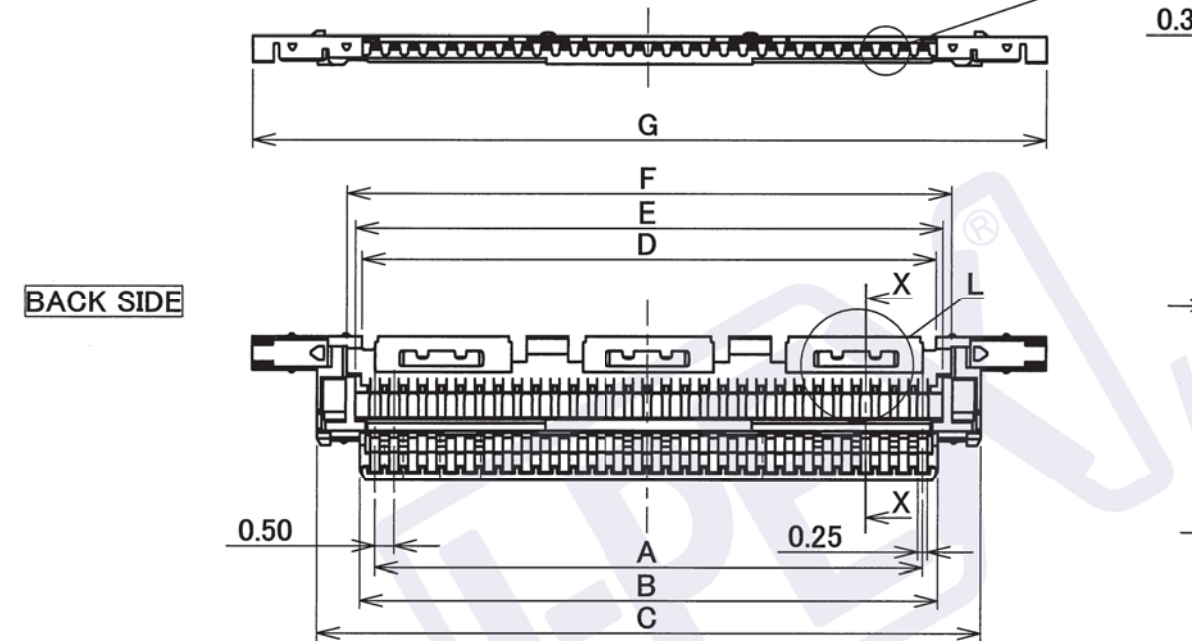
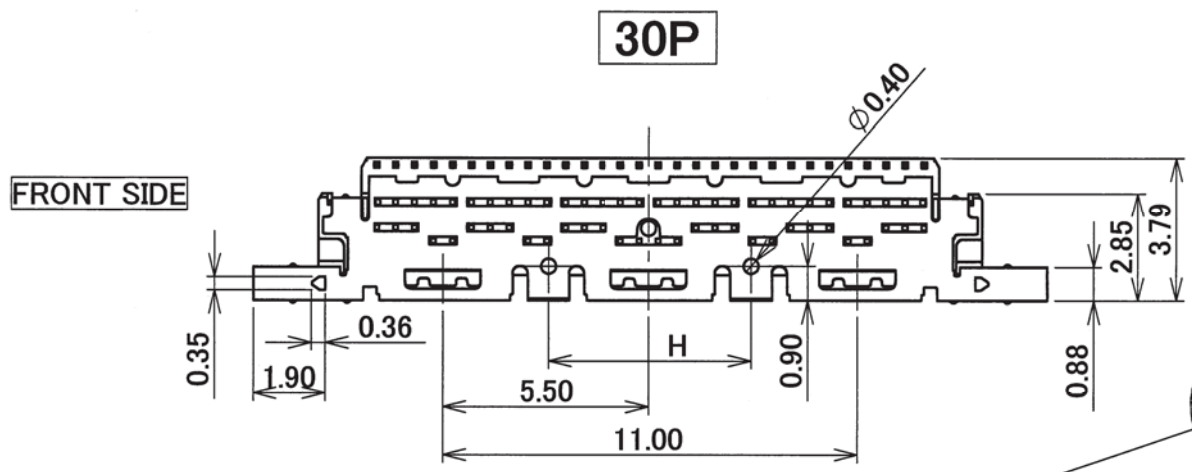

SECT. X-X  
S= 15 : 1

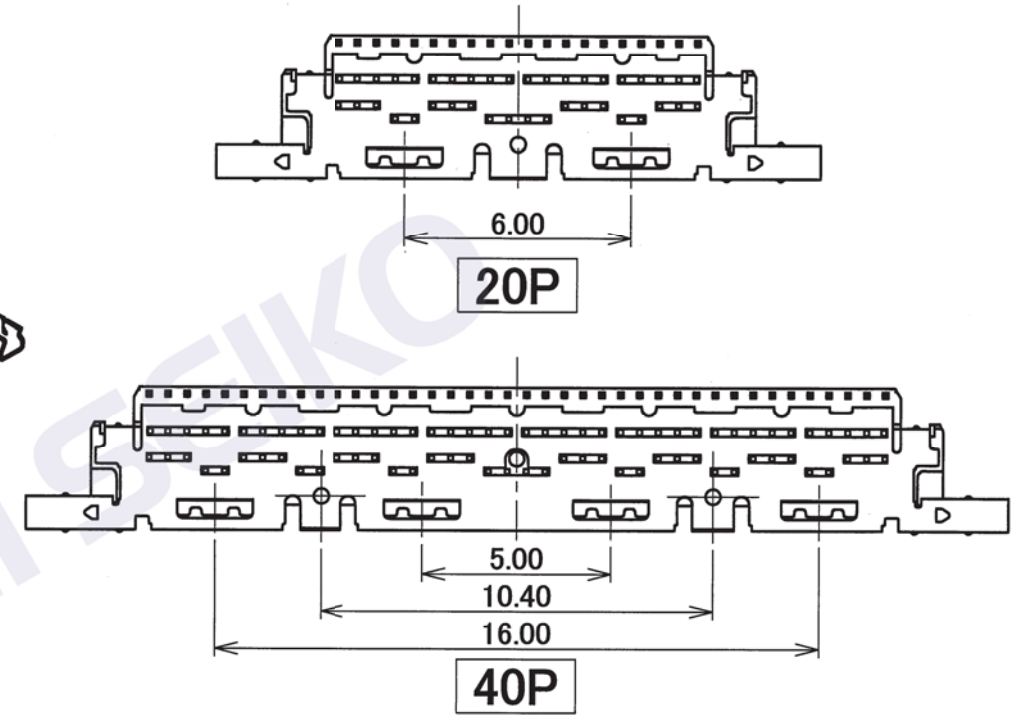

P/N:20454-2 \*\*T  
Pos.  
TYPE-A

- NOTES.
- MATERIAL & FINISH  
 HOUSING : HEAT RESISTING PLASTICS, UL94V-0, BLACK  
 CONTACT : COPPER ALLOY / Au OVER Ni  
 SHELL B : COPPER ALLOY  
 【FRONT SIDE】: Au OVER Ni  
 【BACK SIDE】: Ni (There is the possibility that Au attaches randomly.)
  - THIS PART IS ASSEMBLED WITH SHELL-A(P/N:2574-#\*\*2) AFTER SOLDERED THE CABLE, AND IT BECOMES P/N:20453-2\*\*T-#\*\*.
  - TO ASSEMBLE AND SOLDER THIS CONNECTOR YOU MUST READ AND FOLLOW THE ASSEMBLY MANUAL BELOW.  
 ASSEMBLY MANUAL No. : ASM-08003  
 ASM-08007
  - RoHS Compliant
  - PRODUCT SPECIFICATION No. PRS-1427  
 PRS-1862

PATENT REGISTERED

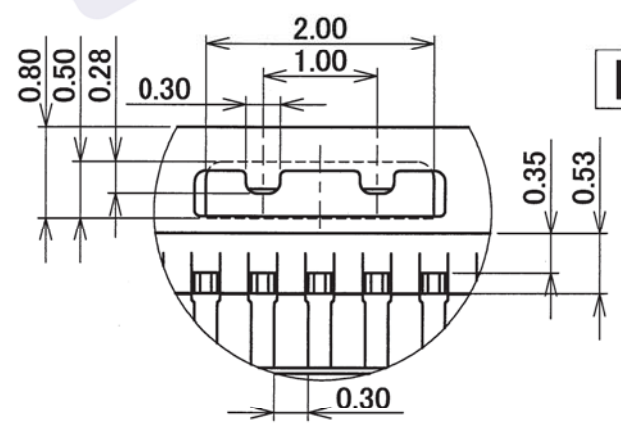

DETAIL L  
S= 15 : 1

GENERAL TOLERANCE	
6 MAX.	±0.2
6 OVER MAX. 30	±0.3
30 OVER MAX. 120	±0.5
ANGLE	±2°

SERIES No.	R10	CUSTOMER COPY	PROJECTION	SCALE	UNIT	DWG. No.	SHEET	REV.
				5:1	mm	20454	1/2	5

**I-PEX** DAI-ICHI SEIKO CO.,LTD.  
I-PEX Business Company

TITLE  
**CABLINE-VS  
PLUG HOUSING ASS'Y TYPE-A**

Confidential C

Recommended P/N

20454-250T-01

PART NO.	POS.
20454-250T-01	50

20454-2\*\*T-01 : TYPE-i

TYPE-A

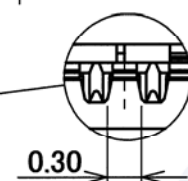
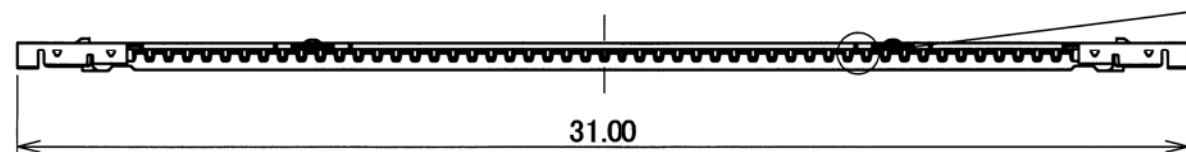
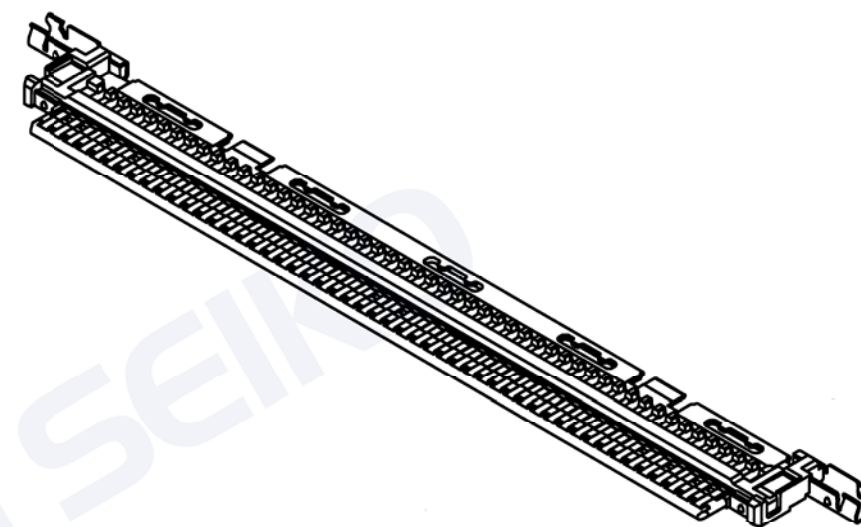
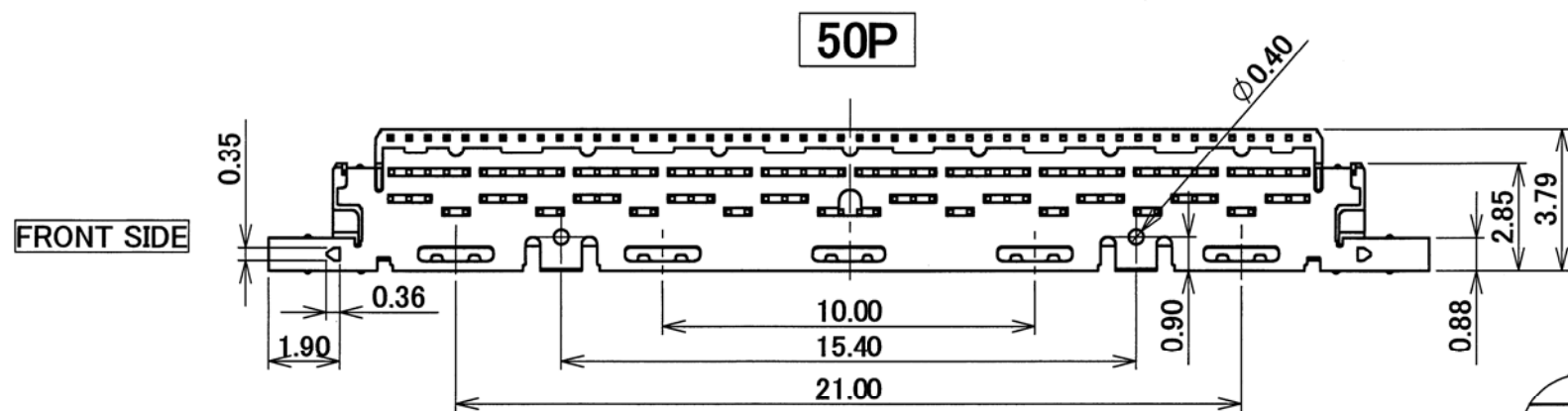

BACK SIDE

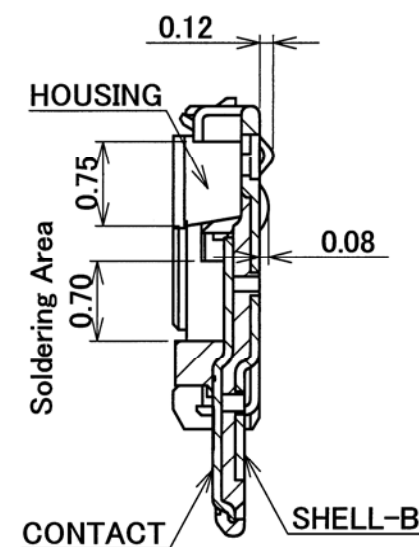
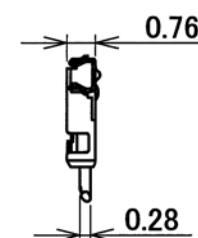
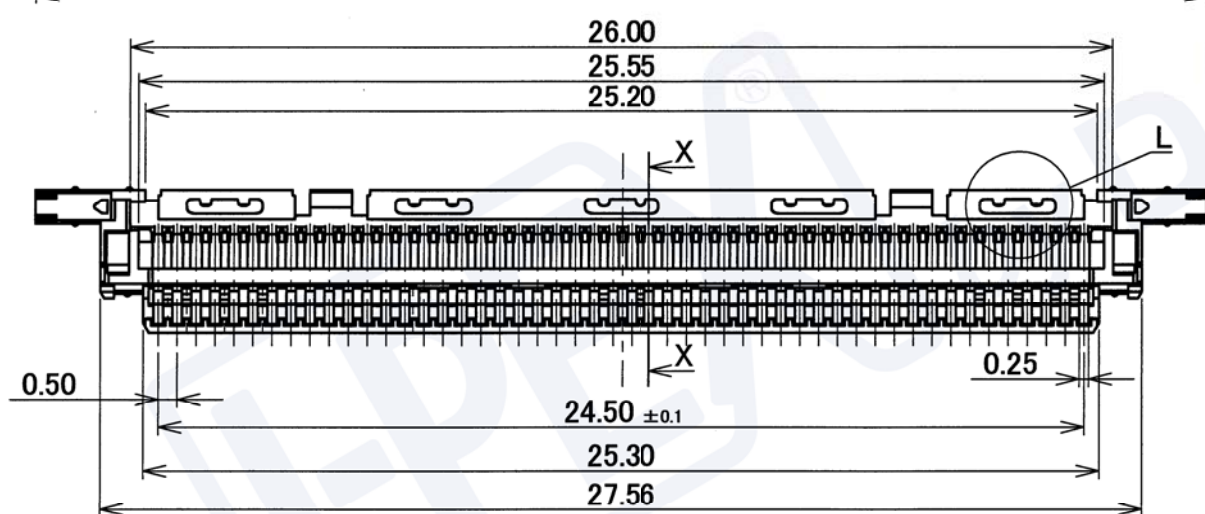

SECT. X-X  
S= 15 : 1

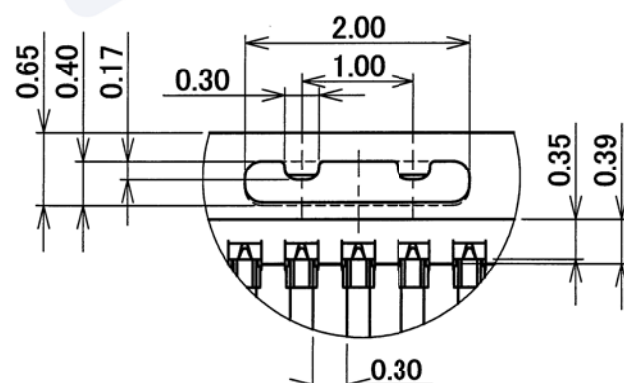

PATENT REGISTERED

P/N:20454-2 50T-01

Pos.  
TYPE-A

GENERAL TOLERANCE	
6 MAX.	±0.2
6 OVER MAX. 30	±0.3
30 OVER MAX. 120	±0.5
ANGLE	±2°

DETAIL L  
S= 15 : 1

SERIES No.

R10

CUSTOMER COPY

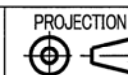

SCALE  
5:1

UNIT  
mm

DWG. No.

20454

SHEET  
2/2

REV.  
5

**I-PEX** DAI-ICHI SEIKO CO.,LTD.  
I-PEX Business Company

TITLE  
CABLIN-VS  
PLUG HOUSING ASS'Y TYPE-A

Confidential C