

**Recommended P/N 20438-0\*\*T-01**

PART NO.	POS.	A	B	C	D
20438-030T-*1	30	17.80	16.80	14.50	20.80
20438-040T-*1	40	22.80	21.80	19.50	25.80
20438-050T-*1	50	27.80	26.80	24.50	30.80

PART NO.	C/T FINISH(MATING SIDE)
20438-0**T-01	Au 0.1~0.3 μm
20438-0**T-11	Au 0.3 μm MIN.

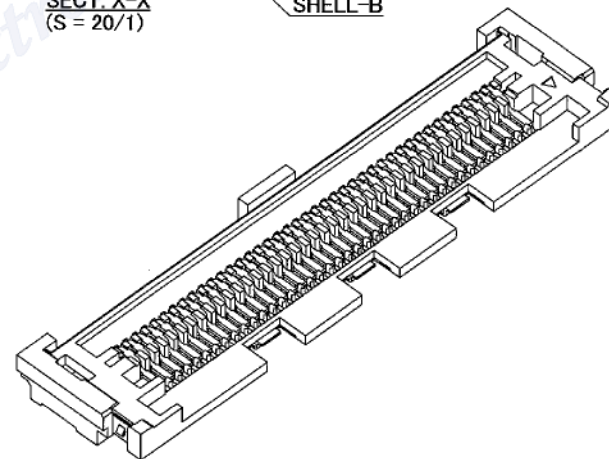
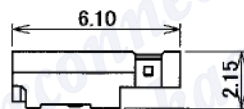
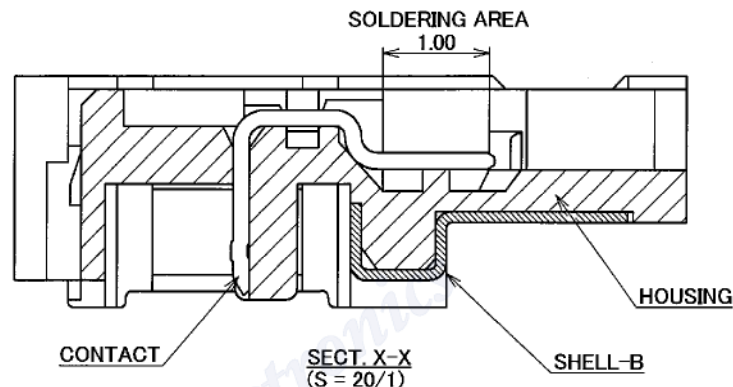
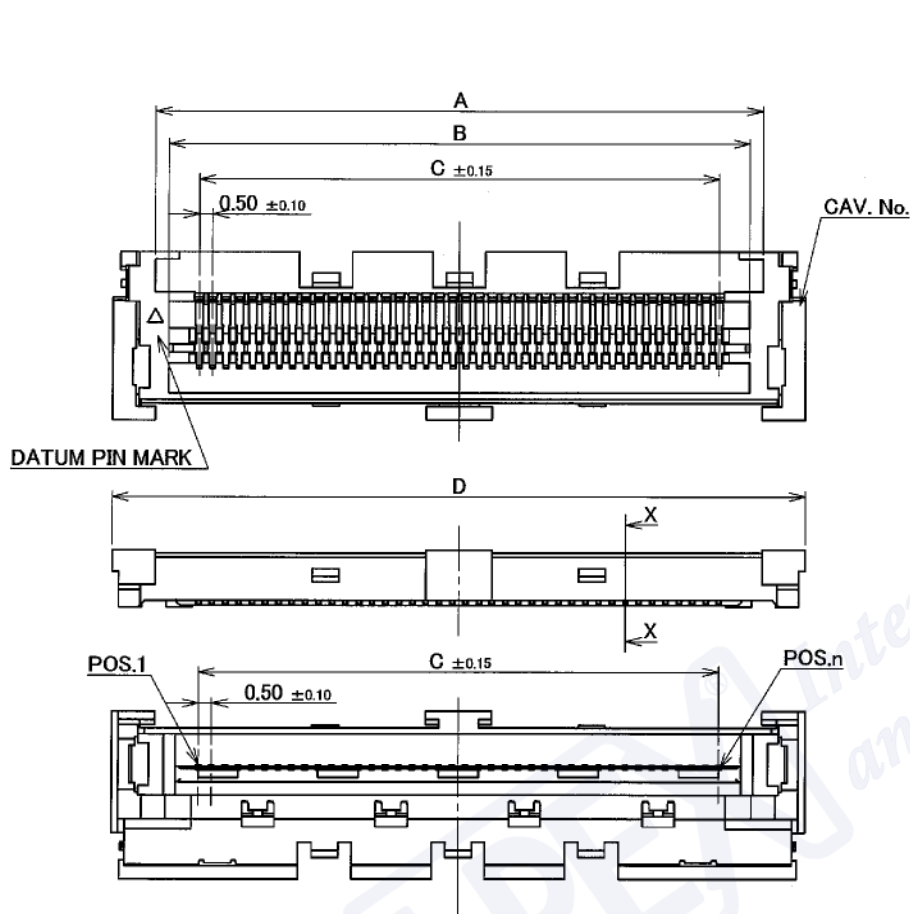

**NOTES**

- MATERIAL**
  - HOUSING : HEAT RESISTING PLASTICS(GLOSS REINFORCED) UL94V-0, BLACK
  - CONTACT : COPPER ALLOY
  - SHELL-B : COPPER ALLOY
- THIS PART IS ASSEMBLE WITH SHELL(2496-0\*\*) AFTER SOLDERED THE COAXIAL CABLE. AND IT BECOMES P/N : 20437-0\*\*T-\*1
- Product specification No. : PRS-1383  
Instruction manual No. : HIM-09007  
Assembly manual No. : ASM-07005

GENERAL TOLERANCE	
6 MAX.	±0.2
6 OVER MAX. 30	±0.3
30 OVER MAX. 120	±0.5
ANGLE	±2°

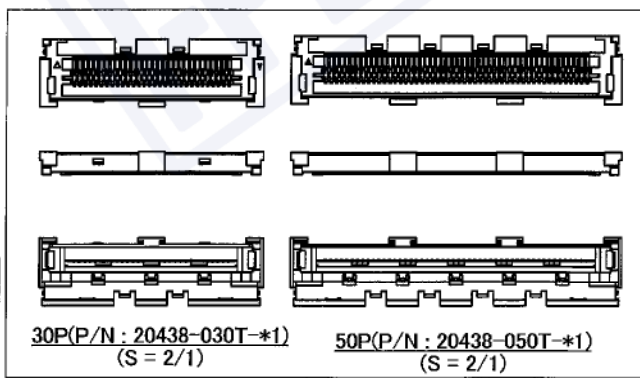

**I-PEX DAHCHI SEIKO CO.,LTD.**  
I-PEX Business Company

TITLE  
**FPL II CONN. PLUG HOUSING ASS'Y**

SERIES No.	R4	CUSTOMER COPY	PROJECTION	SCALE	UNIT	DWG. No.	SHEET	REV.
				5:1	mm	20438	1/1	8